

an ISO 9001 : 2015 Company

RENOWNED
PULP AND **PAPER**
MACHINERY MANUFACTURER



We aim at Consistent Quality Control Customer satisfaction, Reliability & Turn Key Solutions



ABOUT US

Incepted in the year 1995, Harjit Paper & Machinery Private Limited is an ISO 9001:2015 Certified and SGS approved organization, engaged in the manufacturing, exporting and supplying of an all encompassing range of Paper and Pulp making Machines, Pulp Molding Machines. Our range of machinery and equipment is used for making all kinds of paper and boards. Prior to the incorporation of HPMPL, in 1995, we used to function as Harjit Industries, a Proprietorship Firm having same Product Line since 1966.

Mr. Harjit Singh, our mentor supervises our technical team and it is owing to his sharp business acumen that we have been able to create a distinctive identity among our quality conscious clients. His wide experience has helped our organization to deliver work which is at par with the clients requirements and international quality standards. To establish ourselves as a dependable, reliable and trust worthy organization, we aim at consistently providing excellent quality machinery and equipment, and achieve utmost client satisfaction, by following rigid quality parameters.

PRODUCT PORTFOLIO

We offer a comprehensive range of paper mill machinery and related equipment that are manufactured from superior quality stainless steel, mild steel and others. Our assortment is high in demand with our clients from all across the world for their superior performance, durability and competitive pricing. The entire range of our Paper Machinery is bifurcated into two categories namely - Paper Pulp Machines and Paper Mill Machines.

Under the category of Paper Pulp Machines, our highlighted range comprises of ATS Pulper, Hydro Pulper, High Density Pulper, High Density Cleaner, SeparPlast, Turbo Separator, Vibrating Screen, Agitator Assembly, Decker Thickener, Washing Drum, Tri-Disc Refiner, Centri cleaner, Paper Pulp Pump and Pressure Screen.

Designed and developed in accordance with the international quality standards, our gamut of Paper Mill Machines include Paper Machine Headbox, Foudrinier Part, Cylinder Mould, Reformer Machine, Paper Pulp Press, Paper Dryer System, MG Section, Pope Reel, Vacuum Pump and Paper Rewinder.

Some of the salient features of our Paper Mill Machinery are:

- Dimensionally Accurate
- Durable
- High Performance
- Low Power Consumption
- Reliable
- Robust Construction

Moreover, we can also design and manufacture our range of Paper Mill Machinery and other equipment as per the specific requirements of the clients.

MAJOR EXPORTS

We have made and supplied all type of complete Paper Mill Units from concept to commissioning for our customers in Bangladesh, Iran, Doha Qatar, Africa, Sri Lanka, Nepal, Egypt, Oman, Dubai and Turkey on Turnkey basis.

OUR TEAM

Due to the unswerving commitment on part of our team, we have been able to carve a niche for ourselves in the industry. Our industry experts have thorough knowledge about the every equipment and machinery required in the paper industry. Our workforce is divided into different teams of engineers, technicians, quality controllers, sales and marketing professionals and skilled labor.

Our engineers engage in constant study of the latest technological developments in the industry that helps us upgrade our production technology and improve our equipment from time to time. The quality controllers supervise the production process, facilitating us to offer superior quality machinery and equipment to our clients. The sales and marketing professionals engage in constant interaction with the clients and take their feedback that helps us further enhance our range of paper mill machinery and equipment.

QUALITY ASSURANCE

It is our firm belief that the key factor that sets us apart from our competitors is the quality of our range of Paper Mill Machinery and Equipment. We source our raw materials from reputed and reliable foundries and steel makers. We nurture a separate quality control department that keeps a check on all the production related activities.

Starting from the procurement of raw material upto the packaging and storing of the end-product, our quality experts maintain a strict vigilance throughout the manufacturing process, so as to ensure that only premium quality machinery and equipment are offered to our clients. Some of the quality parameters on which we check our paper mill machinery and equipment are:

- Durability
- Dimensional Accuracy
- Optimum Performance
- Low Power Consumption

Our Paper Mill Machinery and Allied Equipments are manufactured using premium quality material and our ISO 9001:2015 Certification is a testimony of the same.

CLIENT SATISFACTION

Since every industry has different requirements, similarly, the requirements of individual clients also differ. Keeping the same in view, we offer customization on the designing and manufacturing of our range of paper mill machinery and equipment. Our clients are welcome to give us their valuable inputs regarding the design and technical specifications and our team of engineers and in-house designers will deliver machinery that is in exact accordance with the same.

Moreover, the packaging of our range of machinery and equipment can also be customized as per the demands of the clients. The superior quality of our Paper Mill Machinery and Equipment, and our wide industry experience has helped us garner an exhaustive and reputed clientele. We regularly export our machinery to various parts of the globe such as India, Bangladesh, Iran, Qatar, Africa and Dubai. Moreover, to provide flexibility to our clients, we accept payment in various modes such as:

- Money transfer through bank
- Letter of Credit
- Demand Draft

WHY US?

Owing to our in-depth product knowledge and excellent performance of our machinery and equipment, we have been able to win the trust of our clients. Some of the factors that make us a preferred choice of our clients are:

- Complete range under a single roof
- Customization
- Packaging as per client requirement
- Prompt delivery
- Ability to undertake bulk orders
- Ethical business practices

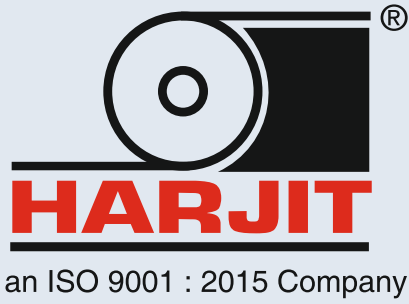

Harjit Paper & Machinery Pvt. Ltd.

Manufacturers & Exporters of: Paper / Board Mill Machinery & Spares

Harjit Paper & Machinery
has exported to following countries:

IRAN



OMAN



QATAR



NEPAL

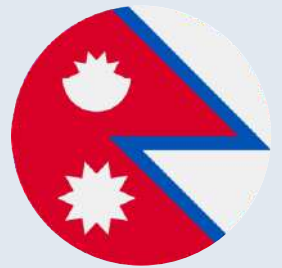

SRI LANKA



TURKEY



AFRICA



DUBAI



SOUTH AFRICA



BANGLADESH

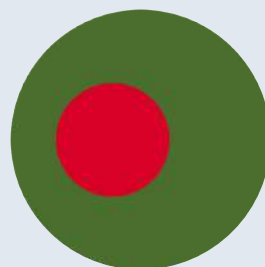



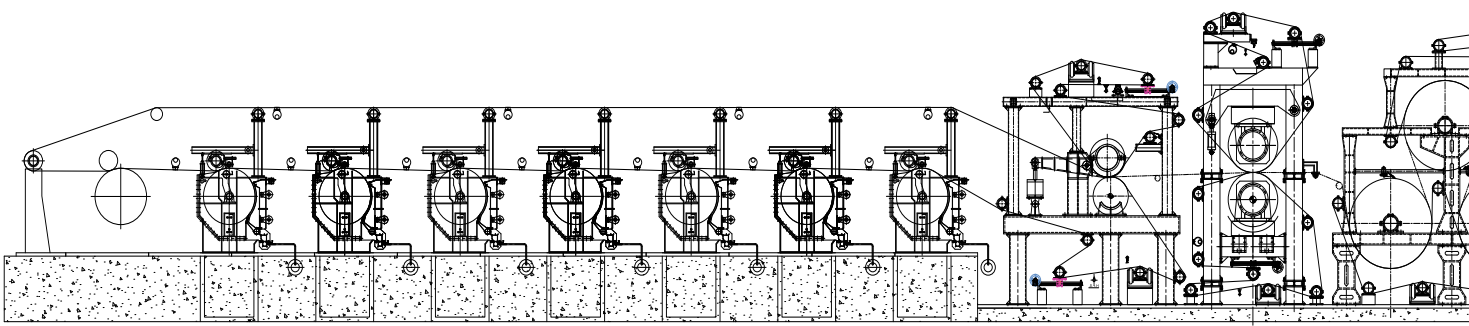
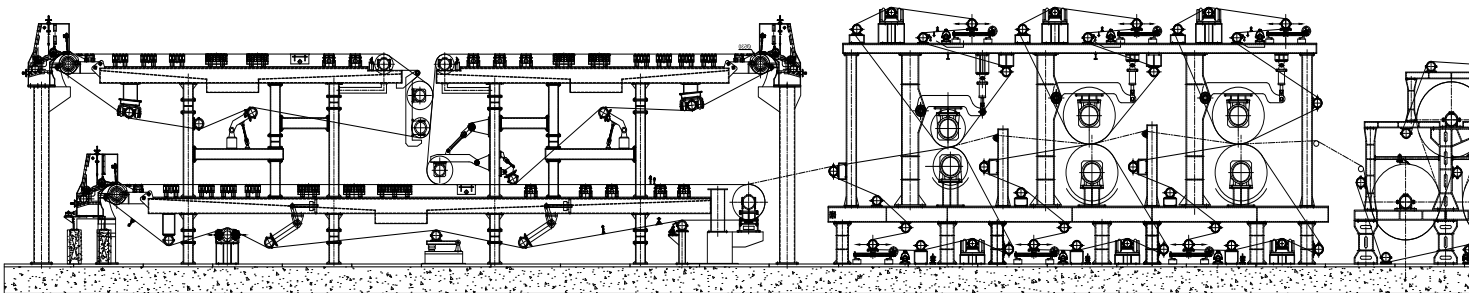
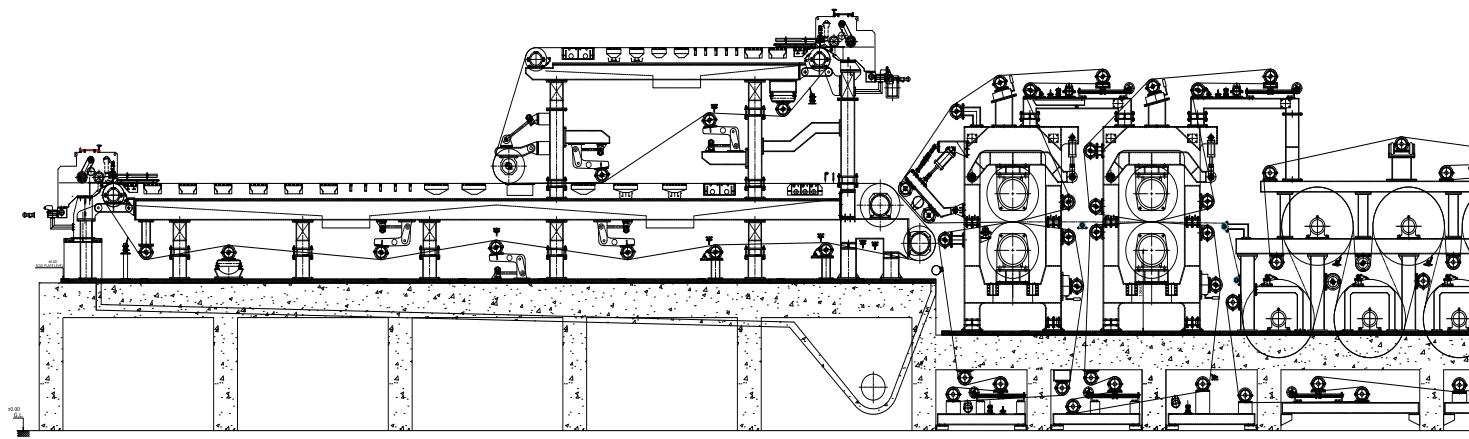
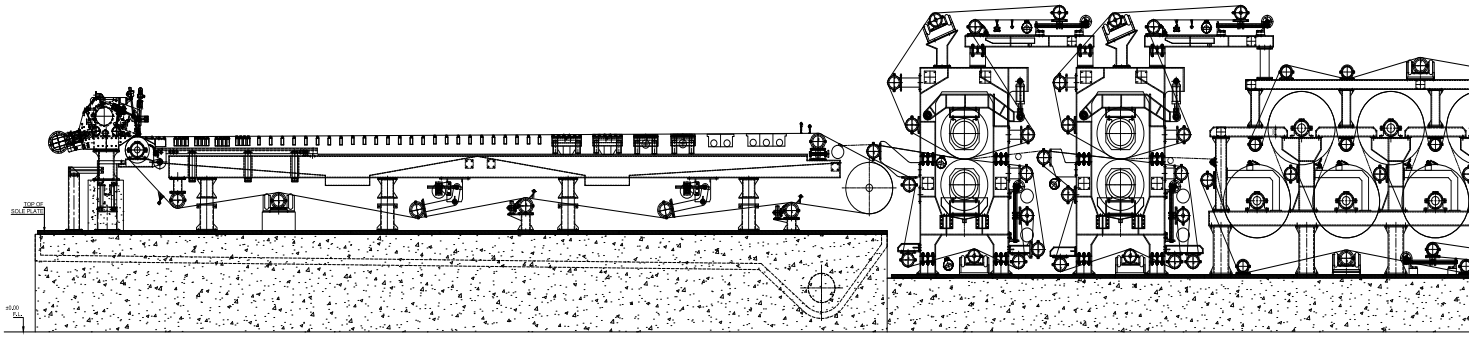

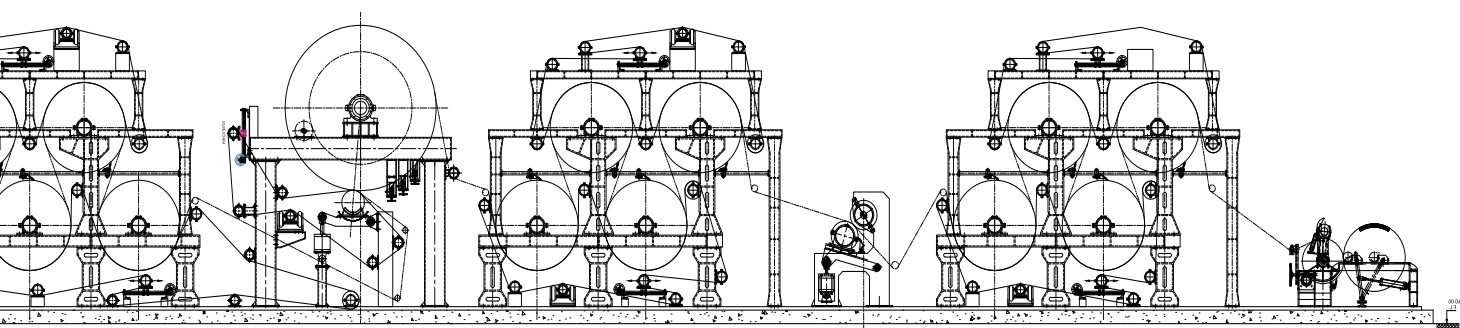
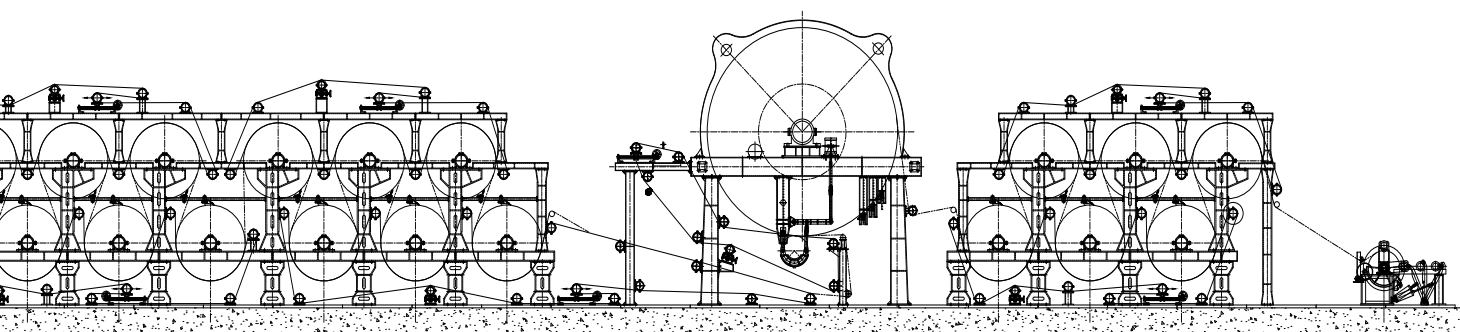
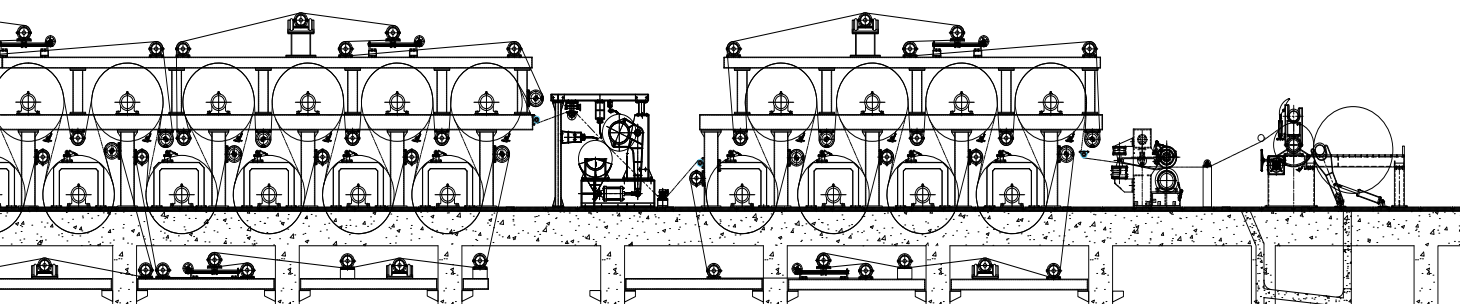
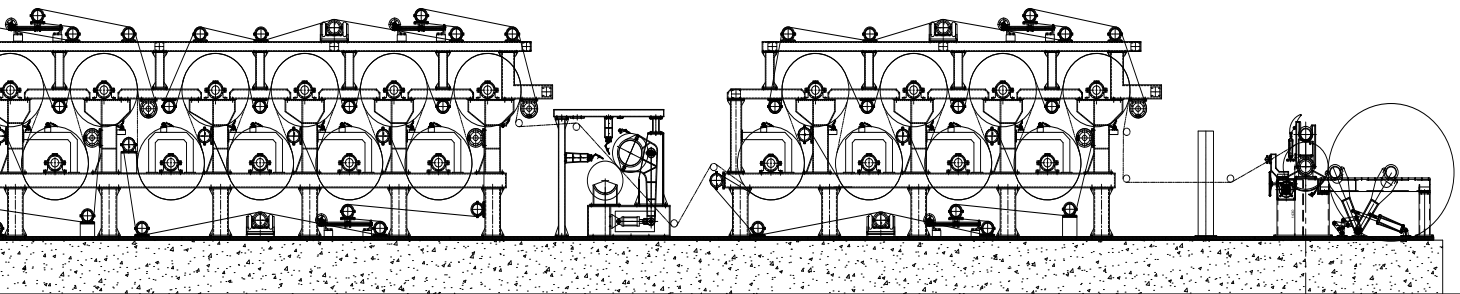



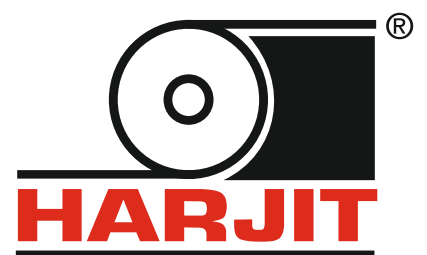

an ISO 9001 : 2015 Company

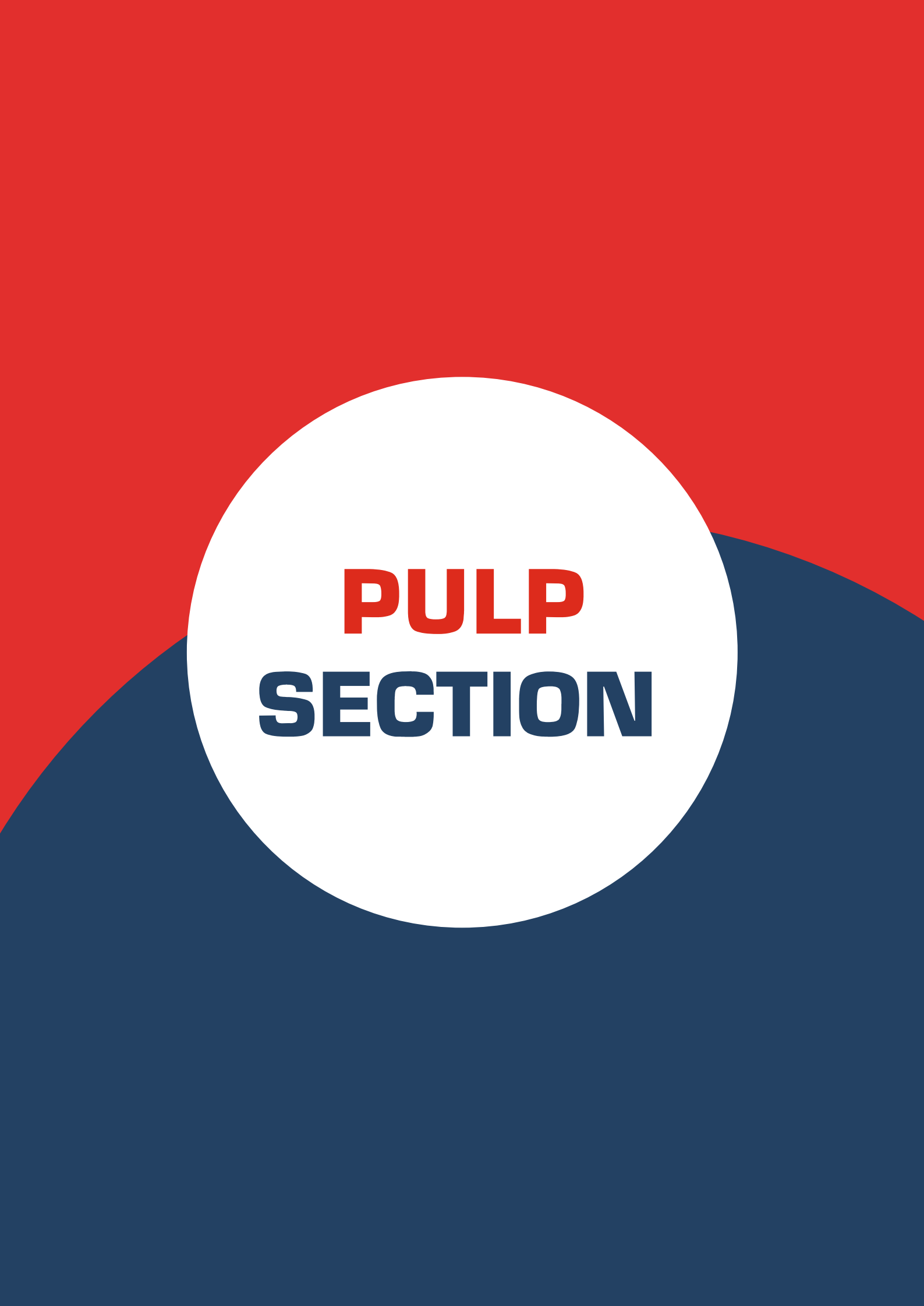

PULP
SECTION

HICON PULPER

1. HICON pulper is a High Consistency Pulper. This type of pulper is equipped with the de-trasher system.
2. HICON pulper operates at consistency 12-16% The special helical screw type design of rotor provides high capacity & low power consumption.
3. It is suitable for slushing of recycled & virgin pulp. This type of pulper is designed for efficient slushing of unsorted waste paper like printed papers, newspapers, laminated kraft, brown grade kraft, wet strength paper, etc. It also serves for detaching the ink from printed papers.
4. Provision for steam injection is given for raising the temperature of stock.
5. The intense circulatory action of rotor provides homogeneous fiber stock quite suitable for deinking process ahead.
5. The slushed stock then diluted to 4-5% consistency and then taken to the de-trasher which further disintegrate the chips and discharges accept through screenplate.



HIGH CONSISTENCY ROTOR :

The rotor is designed in the form of helical screw having three flights. The rotor is designed into different sizes as per capacity of pulper. We provides cast cum fabricated rotor. All the flights are hard faced on working edges. Helps in low power consumption. The rotor is dynamically balanced. Easy to install & gives efficient slushing.

BENEFITS :

It is a batch operation pulper normally with cycle time 25-30 minutes. The consistency obtained is 12-16%. Low power consumption. Pneumatically operated valves. Works in auto cycle with PLC panel. Lower consumption of steam & chemicals. No breaking up of contaminants due low peripheral speed of rotor and easy removal of contraries from stock. Due to the phenomena of fiber to fiber friction separates out the plastic from stock.

CAPACITY & SIZES :

Capacity	6 M ³	8 M ³	10 M ³	12 M ³	15 M ³	20 M ³	25 M ³	30 M ³	40 M ³
TPD	30-45	50-60	60-75	80-90	100-110	120-150	160-180	180-200	220-250
Consistency%	12-18%								
Power (Kw)	125	160	200	250	280	340	450	500	550

DE-TRASHER SIZES FOR PULPER CAPACITY :

Pulper Capacity	6-10 M ³	12-15 M ³	20-30 M ³	30-40 M ³
De-Trasher	TX-700	TX-900	TX-1200	TX-1500

HI-CONSISTENCY PULPER

Features

High Consistency Pulper is suitable for slushing of all type of waste paper at consistency range of 13-18% with minimum fines generation.

It is a batch type pulper having very good difibration effect.

Pulper is provided with a Dilution Pulper with screen plate for removal of non fibrous material, screen plate perforation depending upon the quality of Raw Material.

Most efficient separation of fibre and Contaminants with breaking them up making their Subsequent removal easier.

The quality of disintegrated stock translates into energy saving in terms by refining power.

Less floor space compare compare to conventional Pulper assuming the same daily production.

The low peripheral rotor speed promotes an energy transfer exclusively by friction without shocks nor shearing effect.



D-PULPER

1. The D-Pulper is suitable for the furnish of OCC, AOCC, box board cuttings, virgin pulp, mixed waste, broke kraft, etc.
2. The tub of D-pulper is made up in the shape D. One side of the tub is straight wall and remaining portion is round. This D-shape of the pulper creates excellent turbulence in the tub which helps to reduce the dwelling time. The straight wall of D disturbs the circular flow pattern in the round tub and displaces the vortex which creates a strong nip to submerge the bales of paper.



CAPACITY & SIZES :

Capacity	12 M ³	16 M ³	20 M ³	25 M ³	30 M ³	40 M ³
TPD	60-75	80-110	110-160	160-250	250-300	350-450
Consistency %	4-6 %					
Power (Kw)	120	160	185	220	280	315

BENEFITS :

- Easy separation of fibre with minimum fiber loss.
- D shape provides better vortex to stock and excellently slushes the pulp.
- The operating consistency of this pulper is 4-6%.
- Low specific power consumption.
- It performs continuous operation.
- The trashwell can be equipped as per requirement.
- Low maintenance.
- Removes plastic in large pieces with little disintegration.
- Suitable for medium as well as high capacity plants.

ATS PULPER

Accept Nozzle.

Heavy Contanimants

Light Weight Contanimants Through Ragger

Medium Consistency pulper for slushing of all type of waste paper and Machine Broke

It is a continuos type pulper having very good power efficien

Pulper is provided with S.S. perforated screen plate hole diameter depending upon the quality of Raw Material.

Pulper is available in all sizes suitable for requirement.

Suitable Belt conveyer is supplied for feeding of the raw material (Optional).

Ragger to remove spinning materials like wire, rags, ropes, strings etc. by means of a ragger rage.



TECHNICAL DETAILS ATS PULPER

SIZES TANK CAP. IN M ³	3.5 M ³	5 C	8 M ³	10 M ³	12 M ³	16 M ³
Power requirement in kw	19 KW 30 H.P	30 to 38 Kw 50 to 60 H.P	47 to 62 Kw 75 to 100 H.P	76 Kw 120 H.P	89 KW 150 H.P	118 Kw 200 H.P
Motor Rating KW/HP/R.P.M.	22 KW 30 H.P 1440 R.P.M.	37 to 45 Kw 50 to 60 H.P 1440 R.P.M.	56 to 75 Kw 50 to 60 H.P 1440 R.P.M.	90 Kw 120 H.P 1440 R.P.M.	112 Kw 150 H.P 1440 R.P.M.	150 Kw 200 H.P 1440 R.P.M.
OP. Consistency	4 to 5%	4 to 5%	4 to 5%	4 to 5%	4 to 5%	4 to 5%
Diameter-D	Ø 1700 mm	Ø 2020 mm	Ø 2420 mm	Ø 2616 mm	Ø 2750 mm	Ø 3000 mm
Diameter-C	Ø 950 mm	Ø 1200 mm	Ø 1510 mm	Ø 1510 mm	Ø 1710 mm	Ø 1910 mm
Height-B	1960 mm	2272 mm	2272 mm	2810 mm	3000 mm	3250 mm
Length-A	1850 mm	1920 mm	2206 mm	2376 mm	2600 mm	2900 mm

HYDRAPULPER-VERTICAL

Sailent Features:

- Medium consistency pulper - consistency range 4-6.5%
- Slushing of dry or moist pulp
- Slushing of waste paper, broke, in loose or in bales
- Pulley drive
- Higher model on requirement basis
- Material of construction - S.S or M.S. with S.S lining as per customer scope
- S.S. vane type impeller with hard facing edges
- S.S. perforated screen plate

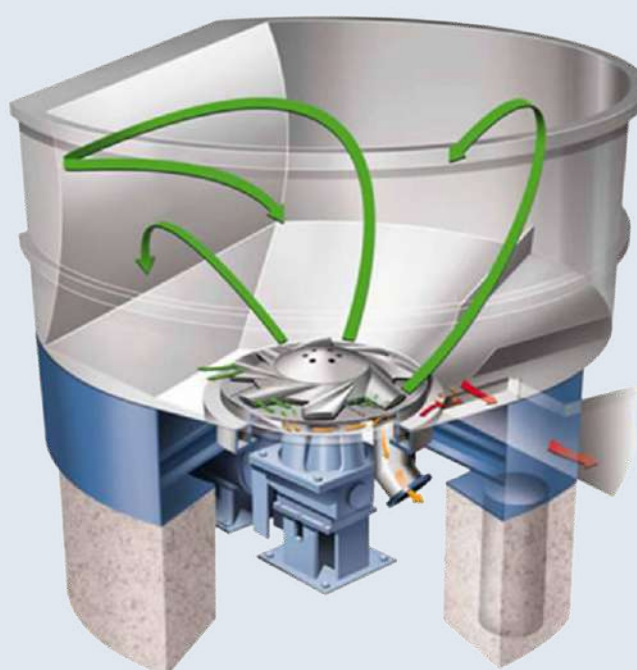

TECHNICAL DATA

Size Tank Capacity M ³	3	5	8	10	12	16	18	20
Power Requirement Kw	19	30	62	76	89	118	142	160
Motor Rating HP* / RPM	30/1440	50/1440	100/1440	120/1440	150/1440	200/1440	240/1440	270/1440
Operating Consistency%		5	5	5	5	5	5	5
Dimentions : d1 (mm)	Ø 1800	Ø 2000	Ø 2300	Ø 2300	Ø 2550	Ø 2900	Ø 3100	Ø 3300
h1 (mm)	2150	2300	2365	2965	2965	3065	3000	3050
h2 (mm)	1675	1800	1825	1825	2025	2400	2800	3000

UTM PULPER

1. The UTM pulper is horizontal type of pulper.
2. in case of paper break on the paper machine the UTM pulper is the optimal solution to pulp all the paper in order to use it for paper making.
3. This pulper gives better deflaking effect.
4. UTM pulper is given with one or two rotor units based on machine deckle.
5. UTM pulper is fitted under the machine and is of low vat height.
6. The paper falling in vat is wetted by showers and is continuously slushed in the vat.

Benefits :

Suitable for wet broke under press section and dry broke under calendar and pope reel of paper machine.

High efficiency of pulping.

Low power consumption.

Stock consistency 3-4%

Compact design with low vat height for effective slushing.

Ease of maintenance

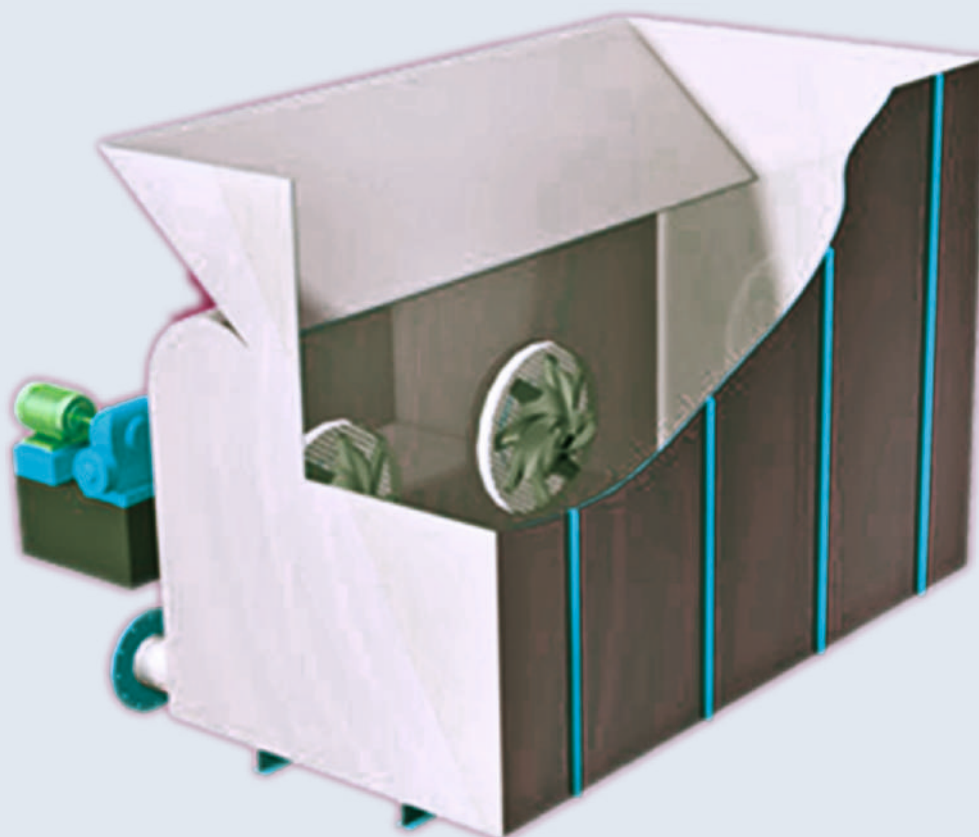

BROKE PULPER

1. The broke pulper is simple design pulper which is installed near the machine in paper mill for handling the machine broke and rewider trims.
2. The purpose of this pulper is to slush the broke for reuse in the paper production. It is used to break down the broke into a stock that can be pumped and treated.
3. The broke pulper comprises of pulper vat, chute, rotor, screen plate, drive, etc.



CAPACITY & SIZES :

	6 M ³	12 M ³	16 M ³	20 M ³	25 M ³
Capacity	6 M ³	12 M ³	16 M ³	20 M ³	25 M ³
TPD	25-40	50-80	80-110	100-160	150-200
Consistency%	3-5%				
Power (Kw)	75	120	160	185	220



Benefits :

The broke pulper is designed to defiber the wet broke, all the discarded paper from paper machine during production. broke pulper is very simple in design but sturdy construction. It can be installed in less space. The broke pulper rotor delivers a high pumping effect with efficient defiberizing at low energy consumption. Easy to operate and maintain. Pulping consistency is typically upto 3-5% Can be operated in either batch or continuous mode.

HIGH DENSITY CLEANER

1. High density cleaner is a device works on the principle of centrifugal action designed to clean the pulp by removing all kind of heavy impurities like sand, glass, staples, chips, etc. It is constructed in SS-304/SS-316 sheet cones.
2. It is a centrifugal type of cleaner which operate on the consistency 2-4%.
3. We provide both motorized as well as non-motorized type of HDC as per requirement.
4. The slushed pulp stock from the pulper is stored in a dump chest. This stock suspension contains lot of heavy and light contaminants.
5. These contaminants are removed from the pulp with the help of centrifugal action formed inside high density cleaner. The consistency is maintained upto 2-3%.
6. Two pneumatically operated valves are provided for the rejects which operate with control panel.
7. The slushed pulp stock stored in a dump chest is fed to the HDC inlet. The tangential inlet accelerates the stock downward and forms centrifugal force due to which the heavier impurities settles down in the reject chamber provided with two pneumatic valves. The cleaned stock rises through the middle of vortex towards the outlet and comes out through the outlet nozzle.
8. The motorized HDC is equipped with the specially designed impeller and motor which helps to force down the stock which results in strong centrifugal action.

Benefits :

- Operating consistency is up to 2-4%
- Eliminates heavy impurities efficiently & effectively.
- Simple in installation and maintenance.
- Low or no power consumption.
- Special design of impeller improves performance.
- Minimum space requirement.
- Improves quality of the pulp stock for further performance and saves the forward machines from wear and tear.



CAPACITY :

Sr. No.	Model	Consistency %	Motor (KW)
1.	1000 LPM		
2.	1500 LPM		
3.	2000 LPM		3
4.	2500 LPM		3.7
5.	3000 LPM	2-4 %	5
6.	3500 LPM		5.5
7.	4000 LPM		7.5
8.	4500 LPM		7.5

TURBO SEPARATOR

Effective separation of heavy and light impurities.

Minimum fiber loss.

Easy maintenance

The body is made out of Stainless Steel with base frame and stiffeners in Mild Steel.

Economy model is fabricated totally in mild Steel with SS cladding in the feed chamber.

A force Vortex is formed in the Separator by the S.S, rotor. The heavy particles are carried outward by Centrifugal force into the junk trap. The rotor and Screen are designed to slush paper chips and remove all the non fibrous material which goes out as light reject and further treated in secondary separator or Johnson Screen.

The accept stock passes through the screen fitted behind the rotor.



Explanation-TS-Tur bo Separator 600-Impeller DIA (mm)

MODEL NO.	TS-600	TS-800	TS-900	TS-1100	TS-1300
Capacity TPD	50-70	70-90	90-100	200-300	350-400
Motor KW / RPM	55 1480	75 1480	90 1480	200-250 1480	300-350 1480
S NB	100	100	100	125	125
L NB	100	125	125	125	200
A NB	150	200	200	300	350
B NB	150	200	200	300	350
d1	1100	1350	1450	1950	2200
L1	1850	2657.5	2860	3100	3800

STOCK CHEST AGITATORS

Agitators

Energy efficient agitators find application in all type of Pulp storage chests, including High Density Towers, Mixing Chest & Machine Chest.

The sturdy design incorporate Bearings & Glands, located outside, optimally designed adjustable propeller blades. All parts coming in contact with stock made of stainless Steel, the agitators are highly energy efficient and have the provision for adjusting the vane angle to suit specific process requirement of gentle or strong agitation.

The agitators help to keep the stock homogeneous during storage with the well designed vanes.

It provides different designs of agitator for different purposes such as Couch Pit Agitators, Chest Agitators, etc.



TECHNICAL SPECIFICATION

AGITATOR SIZE	HORIZONTAL CHEST		VERTICAL CHEST		
	VOLUME (M3)	MOTOR RATING (KW)	VOLUME (M3)	MOTOR RATING (KW)	VANE DIA (mm)
AG 50/60	25 - 100	11 - 15	20 - 40	11 - 15	750 - 1150
AG 75/85	100 - 275	15 - 22	45 - 80	18.5 - 22	1000 / 1150
			85 - 155	30 - 37	1350 / 1550

PRESS PIT AGITATORS

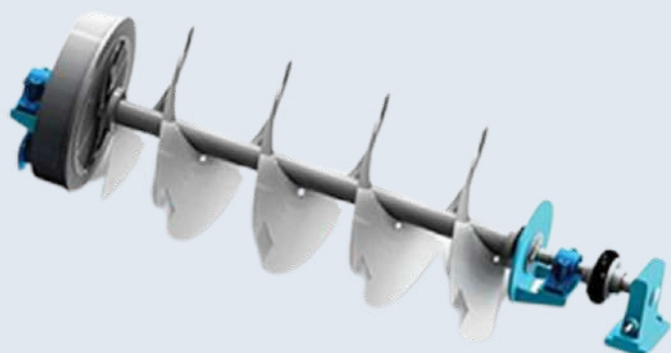

COUCH PIT AGITATORS

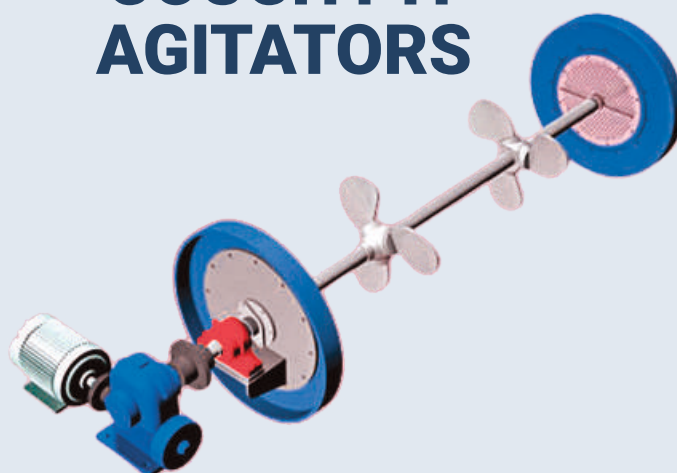

DECKER THICKNER

Decker Thickener comprising of C.I./S.S. Moulds and M.S./S.S. Vat, are best suited for removal of excess water from stock.

Sizes vary from 2.00 mtrs to 3.00 mtrs depending upon the process capacity.

In put Consistency 1% to out put consistency of 4%

Minimum fiber loss due to modified sealing arrangement.

B2 Thickener for Thickening cum washing purpose.

Constructed in S.S. 304 and S.S. 316 Material.

Driven with Variable Speed drive for setting the drainage of different freeness of stock.



SIZE			
DIA	FACE LENGTH	FINAL R.P.M	POWER REQUIREMENT
1220	2000 mm	6 to 8	5 H.P x 1440 R.P.M
1220	2500 mm	6 to 8	7.5 H.P x 1440 R.P.M
1220	3000 mm	6 to 8	7.5 H.P x 1440 R.P.M
1220	3000 mm	6 to 8	10 H.P x 1440 R.P.M
1220	3500 mm	6 to 8	12.5 H.P x 1440 R.P.M

TRI DISC REFINER

1. In stock preparation refining is considered as the most important stage in paper making process. Refining is the backbone in stock preparation stage as well as in paper making.
2. This determines the quality of paper and furnishes composition and power consumption.
3. Thus every paper mill is trying to adopt latest technology in refining.
4. The disc refiner is suitable for coarse refining and fine refining of various pulps such as wood pulp, cotton pulp, waste paper pulp, etc.
5. We provides two types of disc refiners double disc refiner and tri disc refiner.
6. Compact structure with less area required. It gives highly efficient production with low power consumption.

Features :

Easiest design with best profile of on the discs.

Loading and unloading with hydraulic power pack system.

Fully automatic control.

Satisfy the paper making demand.

Suitable for various raw materials like wood pulp, waste paper pulp, etc.

With feature of long refining area strong ability to disintegrate fiber.

Adopt constant power control system and gives stable beating effect.

SS-304/special composition steel rotor and stator with various numbers of teeth.

MODEL	TDR-17		TDR-21
CAPACITY (TPD)	20-50		45-75
CONSISTENCY %		3-4%	
MOTOR (KW)	110-150		250-315

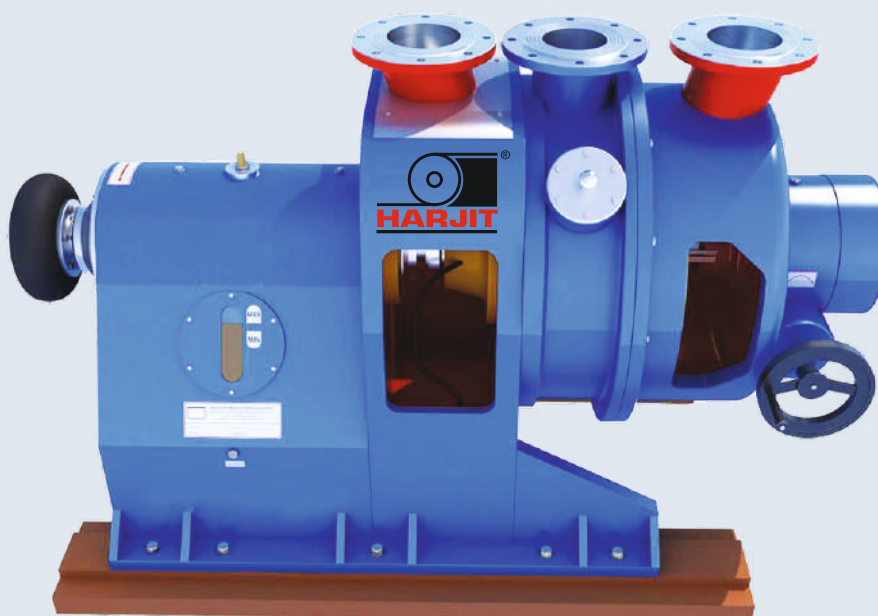

CENTRICLEANERS/ LOW DENSITY CLEANER

1. Centricleaner is the low density cleaner. It works on the principle of vortex formation by centrifugal action.
2. It is the simplest type of device made in SS-304/SS-316 with tangential inlet. It is designed to remove air, dirt shaves and specks from pulp efficiently and effectively.
3. It works at the consistency upto 0.5-1%.
4. The reducing diameter of the cone ensures good performance of the device by producing strong centrifugal action.
5. The diluted stock of consistency between 0.5-1% enters in centricleaner through its tangential inlet. Tangential entry of the stock accelerates downwards. The centrifugal force causes the strong vortex action at the center of bottle. Due to this cleaned pulp stock rises through center of bottle toward outlet pipe.
6. During this process the contaminants like dirt, specks, dust, and large ink particles are forced downward.
7. The centricleaner is provided with individual manually operated valves at inlet and outlet of the bottles.
8. Number of centricleaner bottles can be installed in number of stages for better performance and to reduce fibre loss.
9. The centricleaner cones are available in SS-304 body and Ceramic body as per customers requirement.
10. At the bottom nylon polypic/ceramic nozzles are used which can be easily removed for cleaning and replacing.

Features :

Simple design and easy to install.

Easy operation and low maintenance.

Its operating consistency is 0.5-1%.

Efficiently removes impurities like dirt, dust, shaves, spikes, etc.

Improves the quality of the pulp.

Reducing cone diameter results in outstanding cleaning effect.

Lower inlet pressure.

Less plugging.

Ceramic or nylon polypic nozzles are used at bottom for removing rejects

In number of stages of centricleaner the reject of first stage bottles becomes the inlet stock for second bottles which results in minimum fiber loss and high efficiency.

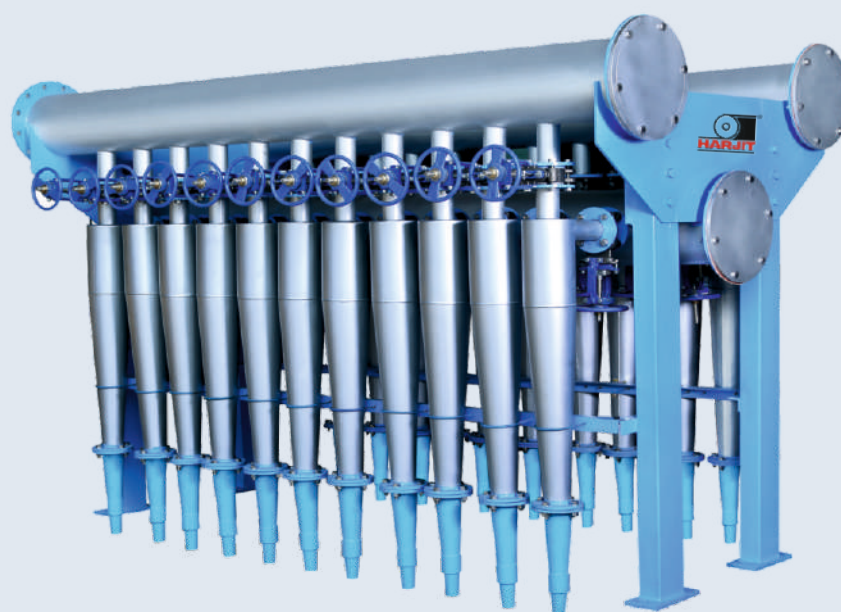

MEDIUM CONSISTENCY PRESSURE SCREEN

1. Medium Consistency Screen with special design of Hurricane vane type of rotor is provided with hole / perforated / slotted basket.
2. The function of the medium consistency rotor is to remove the shaves and heavy sand particles and hard contaminants from the furnish.
3. It is the coarse screening machine which is equipped at coarse screening stage after the high density cleaners.
4. The typically designed Hurricane type rotor and perforated basket allow the accept to go out and retain the contaminants and pass through the reject nozzle.
5. The Hurricane rotor is the specially designed rotor and is a fabricated rotor. Contoured foils generate lower positive pulse and higher negative pulse, hence low energy consumption and gives higher purging effect to keep the basket clean.
6. The rotor is suitable for operation with large flat shaped contaminants. The rotor is perfectly dynamically balanced.
7. The medium consistency screen can work upto consistency 1-3.5%.
8. The material of construction is SS-304 and M.S.



Features :

- Operates at low consistency 1-3.5%
- Suitable for coarse screening.
- Low power consumption.
- Gives better result with efficient separation of contaminants.
- Improved screening capacity.
- Easy to operate and low maintenance.
- High production capacity as well as accept capacity.
- Clean accepted stock.

LOW CONSISTENCY PRESSURE SCREEN

1. Low consistency pressure screen is fine screening equipment designed to remove all the impurities like specs, thermocols, plastic, etc. from the pulp stock.
2. This screen is suitable for the stock preparation system in fine screening stage and it is also suitable for the approach flow system.
3. This screen is equipped with the slotted / hole basket and aerofoil type rotor.
4. The slotted / hole basket consists of the number of wedge wires connected or welded together. The different slot sizes of baskets are available from 0.15 to 0.45mm.
5. Specially designed aerofoils vanes are used for the rotor which ensures that the screen operates free from pulsation.
6. The aerofoil design of vanes creates positive as well as negative pulses. Positive pulses push out the stock whereas the negative pulses keeps the basket slot clean.
7. The unique contoured multi-foil rotor with optimum foil angle ensures better screening efficiency.
8. The material of construction is SS-304 and M.S.

Features :

- Operates at low consistency 0.5-1%
- Low power consumption.
- Improved screening efficiency.
- High production capacity as well as accept capacity.
- Improved quality of paper.
- Mainly used for fine screening and approach flow.
- Specially designed airofoil vanes of the rotor.
- The rotor is perfectly dynamically balanced.
- Low pulsation due to gentle screening.

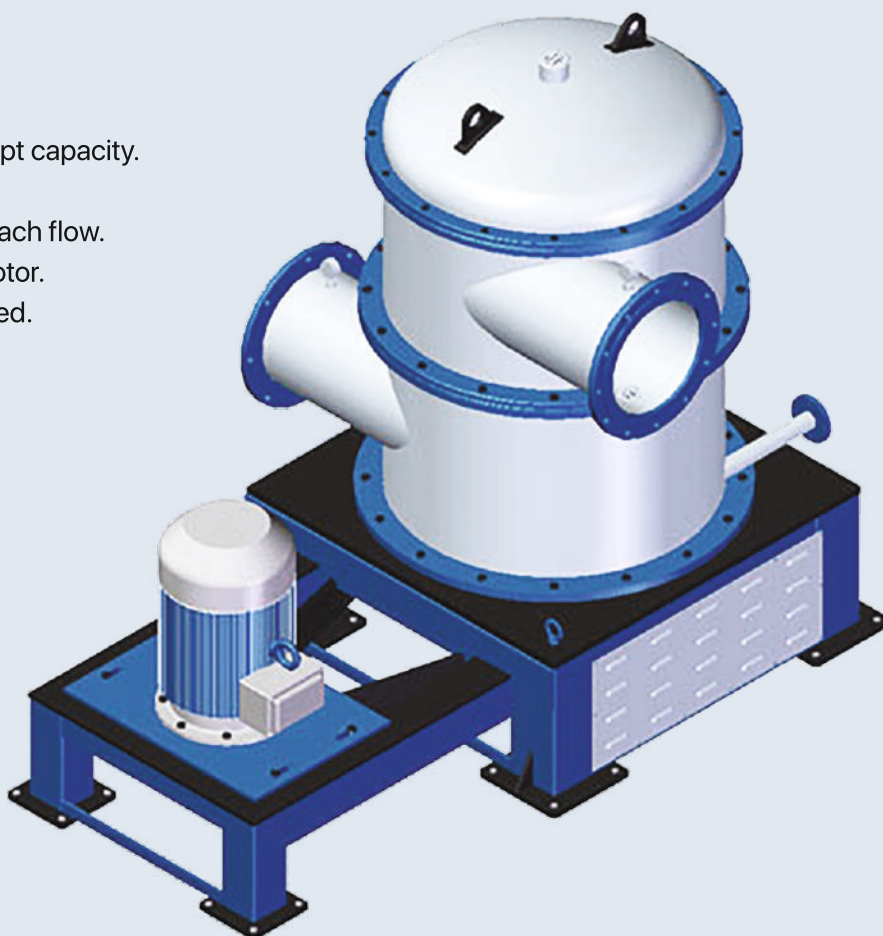

REJECTO SORTOR

1. It is the typical last stage coarse screen. It is used as a tail end reject handling system for continuous removal of light contaminants
2. The specially designed rotor is fitted with the sweeping vanes which impells the stock fed against the screen and segregates the contaminants
3. It is the best replacement to the vibrating screen. It is suitable for handling higher reject contaminants.
4. It gives effective removal of contaminants with minimum fiber loss.
5. Gives higher fiber recovery and gravity discharge.

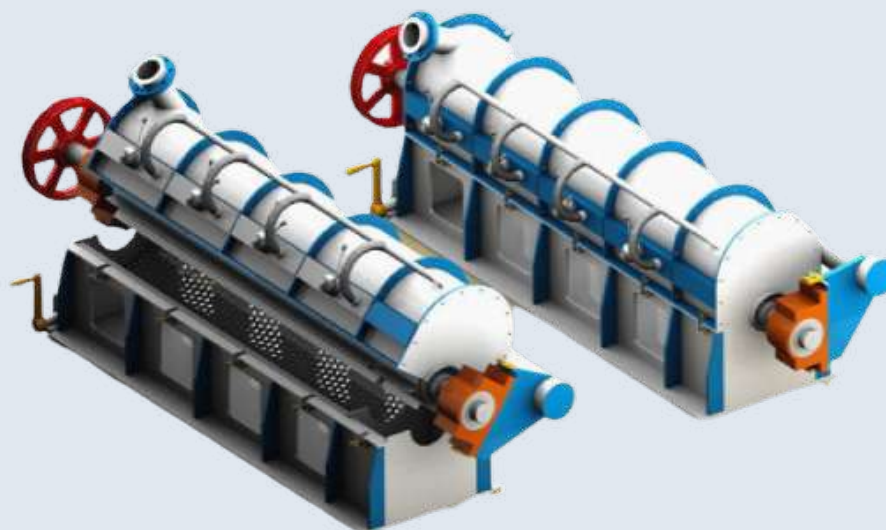

VIBRATING SCREEN

1. Vibrating screen provides perforated vibrating screen
2. It is the last stage equipment in screening for recovery of fiber and removing various impurities.
3. Vibrating screen is widely used for coarse screening of different kind of pulps.
4. It is equipped with special vibratory motor having varying amplitude and allows low power consumption with high efficiency.
5. It works on the principle that vibratory motor is fixed on the cradle suspended on the four heavy duty helical springs providing controlled vibration.
6. The screenplate is in special grade of plastic sheet Derlin

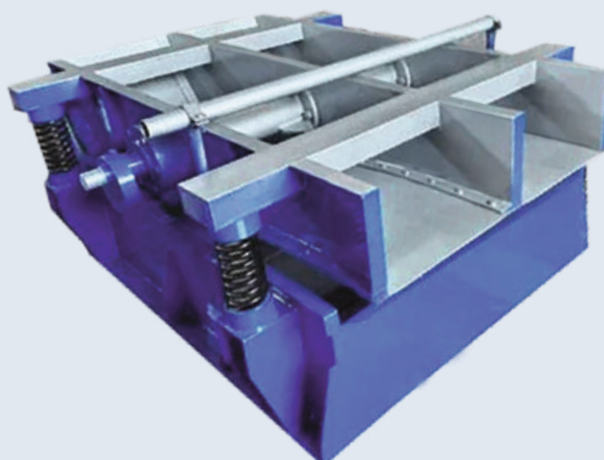

ECO DE-INKING SYSTEM

1. The purpose of de-inking system is to remove the printing inks and other substances like stickies that might affect the paper making process or the final paper.
2. It is designed to remove hydrophobic impurities such as ink particles, plastics or fillings in waste paper stock.
3. In de-inking process the ink should be first detached from the fiber.
4. The floatation cell technology with high efficiency provides high yielding of the fibers and easy handling with maximum operating reliability.
5. It is able to remove wide range of ink particles from 5-500 micron.
6. This system is easy to control the fluid level which results in reliable operation and a wide range of capacity.
7. Two stage floatation systems ensure the maximum removal of impurities with minimal fiber loss.
8. This de-inking system is compact and requires less space.

Features :

- Compact design and requires less space.
- Highly efficient and low power consumption.
- Less maintenance.
- High consistency scum and less fiber loss.
- Highest possible degree of brightness can be achieved.
- Improved optical cleanliness in recovered paper stock.
- No pollution, environment friendly.

ECO DE-INKING SYSTEM

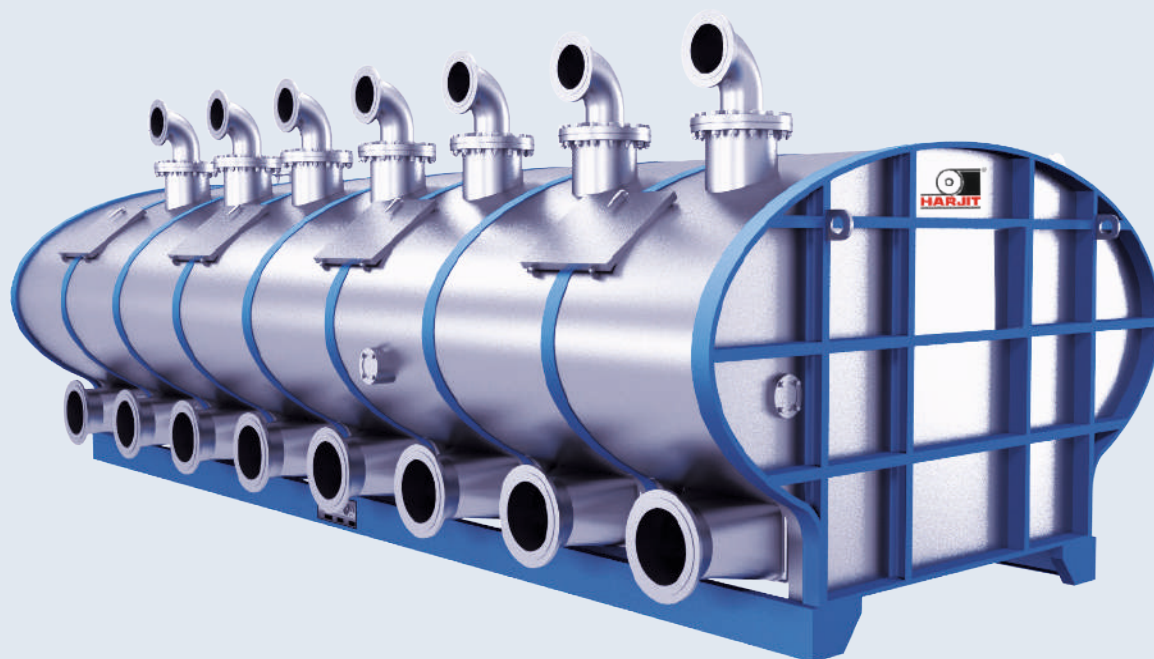

DISPERSION SYSTEM

1. The dispersion system consists of the components dewaterer, plug screw and shredder, screw press heater mixer, disperser and control system.
2. In the heating screw, the pulp with the consistency of 25-30% is heated to 80-130°C and mixed with the chemicals.
3. Then the pulp enters the feeding screw in the form of round particles. Through the screw rotating disc in the disperser the pulp is extruded into the 0.1-0.5mm gap between the fibrillating fluted moving disc and fixed disc.
4. Then the pulp goes through the crushing and refining zones between the fluted discs. Between the fibrillating fluted discs the pulp will be mechanically and physically acted intensively and evenly rubbed and softened so that the hot melt material, adhesive material and ink, etc. will be peeled off from fibers and dispersed into invisible, small particles and pulp gets mixed with the chemicals evenly.
5. The dispersion system is controlled by the hydraulic and electrical control system automatically. The control system is equipped with the position sensing device in order to control the gap between discs.

Features :

- Low power consumption.
- Easy to operate and control.
- Easy to install and maintenance.
- Automatic hydraulic and electrical control system.
- Compact and requires less space.

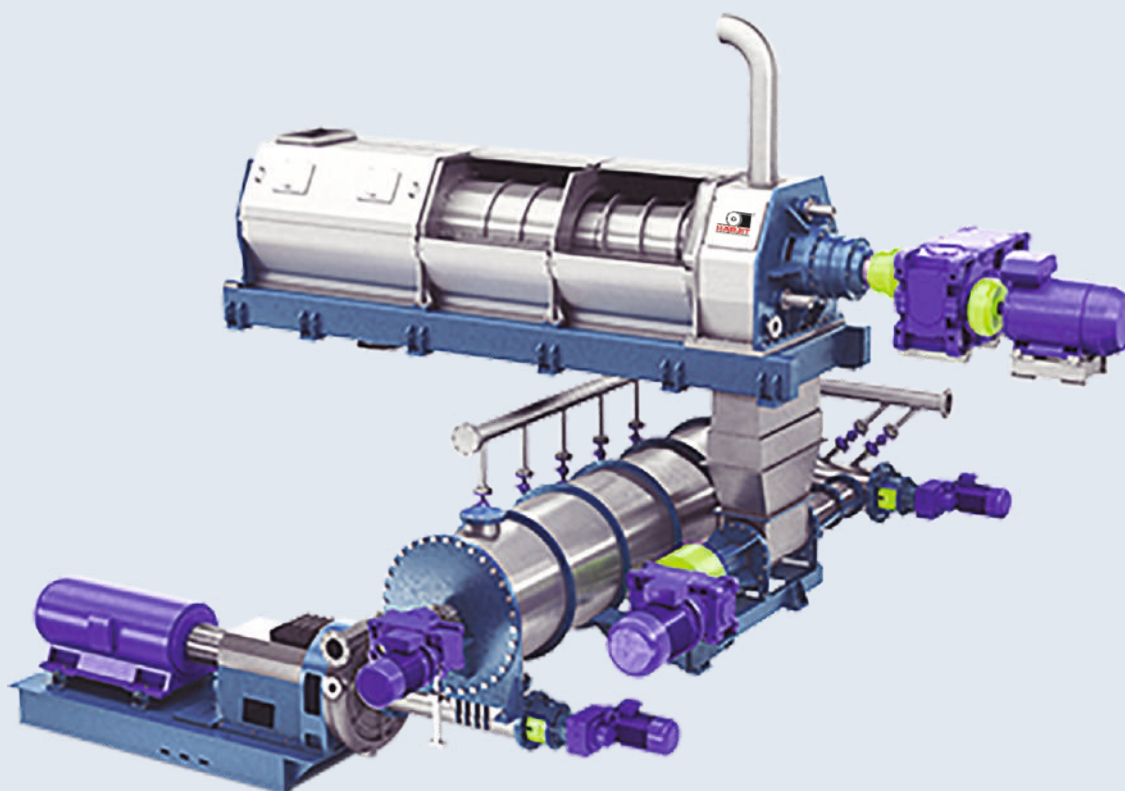

**DISPERSION
SYSTEM**



**PAPER/
PAPER BOARD
MACHINE
SECTION**

HEAD BOX IN PAPER MACHINE

The head box in paper machine is an equipment that offer terribly low consistency stock into the forming section uniformly. The formation and uniformity of the final word paper product depends on the dispersion of the fiber and fillers. A well made Head box in paper machine will give top quality board and better productivity.

Head Box Family comprises of an optimum choice of head box in paper machine to meet different production needs in paper and board making. New modern head box solutions, blended with the accurate dimensioning knowledge of current technology, improve the functioning of your paper machine to a totally new degree.

Open Type, Air Pressurised, Hydraulic Headbox



Head box provides

- Top end-product quality
- Improved productivity
- Lesser life cycle costs
- Assured investment

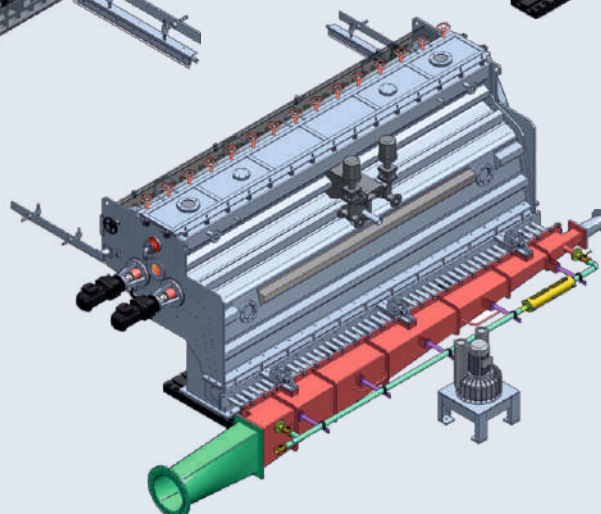
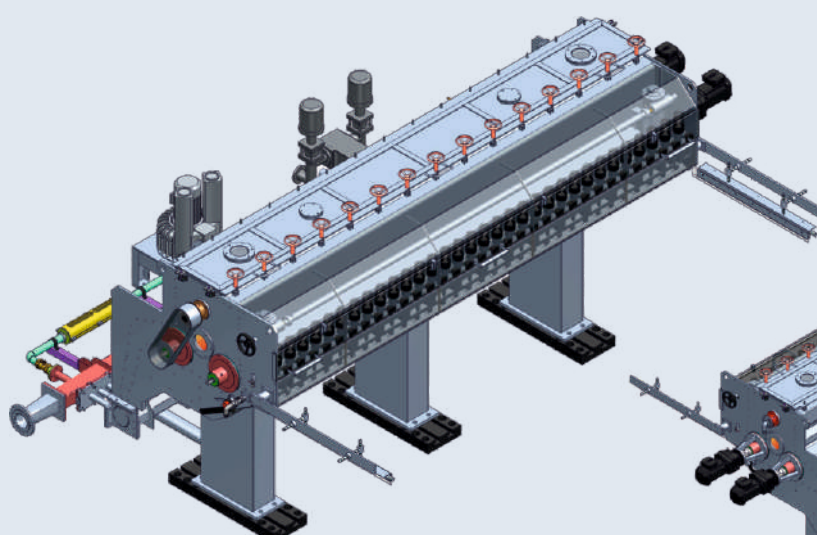
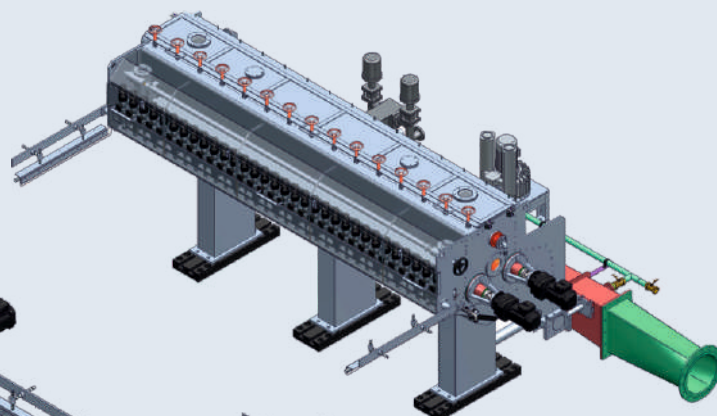

PAPER MACHINE FOURDRINIER

Multi-Fourdrinier Provides

- Cost-effective concept with two, three, four or five Fourdriniers
- High drainage and production capacity
- Wide basis weight range with good sheet formation
- The bespoke concept for ef effective usage of raw material

Fourdrinier Machine assures high efficiency and output. The flexibility to make products across a broad range of grades is also often required, and white lined chipboard, folding boxboard and coated SBS can all be produced on the same multi-Fourdrinier machine. With this flexibility, production can be targeted at the best market potential and the highest value.

Multi-Fourdrinier

A Fourdrinier Paper Machine Forming Section delivers gentle dewatering and high strength yield. The length of the Fourdrinier Machine forming table is designed for furnish used. The concept is cost-effective and provides good product properties throughout its operating range.

Servalls exclusive product range also provides rebuild solutions for conventional Fourdrinier formers to improve end-product quality and output, or to enter a new GSM range or board grade.



PAPER MACHINE PRESS PART

- Press Section is designed considering the quality of the Paper & Paper Board.
- High Efficiency presses with Blind drill coating on top and bottom roll with top felting arrangement for high speed.
- Presses suitable upto 200 Kg/Linear cm are available.
- Heavy Duty Press up to the finished diameter of 1500 mm are in regular supply.
- Heavy Duty Framing with Hydraulic or pneumatic loading system.



BI-NIP PRESS

Centre roll based press section advantages:

- Compact design in New Lines & easy to apply in rebuilds
- Improved dryness and good moisture profiles
- A dependable concept with many references both in Paper and board machines
- Added capacity potential in rebuilds



PAPER MACHINE DRYER SECTION

- M.S. (B.Q. Plate) Fabricated Drying Cylinders with high evaporation rate.
- Available in 4 feet, 5 feet and 6 feet diameter.
- Shell thickness varies from 25 mm to 36 mm
- Operating Pressure up to 4.5 Kgs/ Cm 2 and specially designed for higher working pressure upto 6.0 Kgs/ Cm 2
- Suitable Heavy Duty framing in Graded Cast Iron and Mild Steel fabrication for the maximum coverage of paper at dryer.
- Rope feeding system is provided for Machine speed over 200 MPM
- Framing is designed for Ground Floor as well as 1 st Floor Machine
- Dryer surface ground finish to Ra 8 micron balanced dynamically to grade of 6.3 (ISO 1940)



M.G. CYLINDER

- MS fabricated M.G. Cylinder up to 16 feet (4.88 meter) diameter.
- Width upto 4.00 mtrs is in regular production.
- SS Coating on surface (Optional)
- Stress relieved for removing stresses developed during bending and fabrication.
- Surface is machined and ground to achieve Mirror finish on the surface - Finish Ra 8 micron.
- Scooping system is provided to remove condensate efficiently.
- Heavy duty framing is provided for vibration free operation.
- Single and double Touch roll is provided depending upon the process requirement.
- Spur Gear and pinion in Cast Iron/ MS Fabrication/ polypick, teeth are geometrically evenly cut on precise Hobbing Machine for noise free operation.
- MG Cylinder is designed to operate on working pressure up to 6.0 Kgs/cm².
- Hydraulically tested to a pressure of 11.0 Kgs/cm² and held for 24 hrs.



SIZE PRESS & ONLINE COATING STATION

Size Press

- Inclined size press designed for on line sizing on the paper/paper board.
- Rolls are lined with special rubber suitable for surface sizing.
- Size kitchen in SS construction.

Online Coating For Duplex / Triplex Board

On Line coating station basically comprises of composite coater. Control Panel, Hot Air Drying section and Steam Heated Drying Cylinder.

- Coater will comprise of pneumatically actuated applicator roll. Backing roll and pneumatically loaded metering bar.
- Control Panel comprise of VFD based variable speed drive for Applicator roll and Metering Bar.
- Hot air drying system compromise of Air Heater, Hot Air Blower and Exhaust System for the initial drying of coated Paper Board after coating.
- Steam Heated Drying Cylinder duly chrome coated for the final drawing of Coated Paper Board.
- Complete Coating Chemical Kitchen in SS construction compromise of Chemical Cooker, Double speed Dispenser Vibro Screens, Screw pumps and storage tanks are in standard scope of supply.

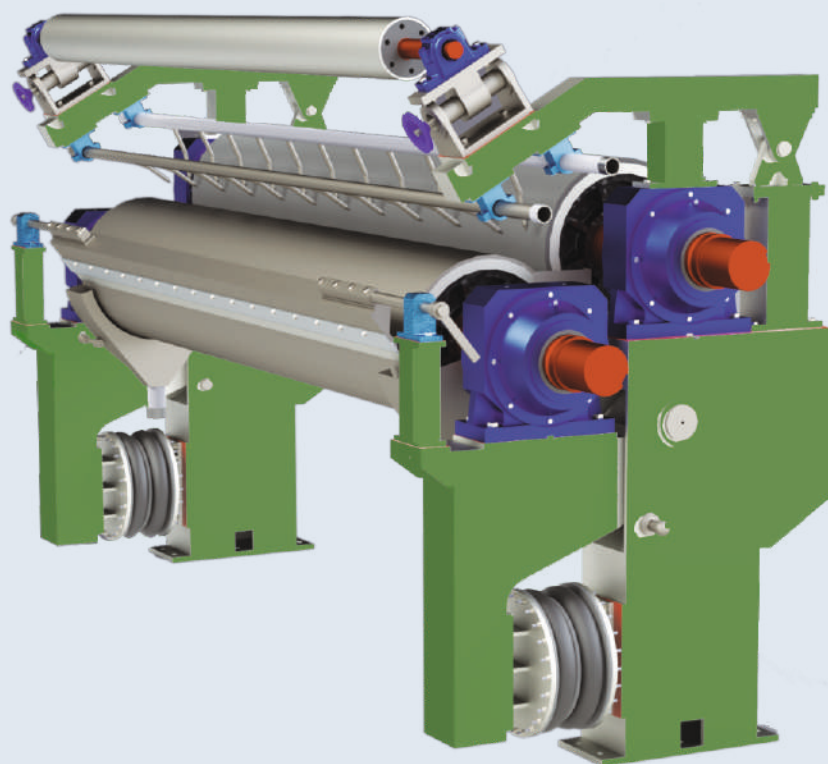

POPE REELER

- Pope Reefer is designed on the principal of Friction Winding.
- Primary Grab Arm is Pneumatically / Hydraulically loaded and tilted Hydraulically/mechanically with manual operation.
- Secondary arm is loaded Pneurnatically/Hydraulically
- Pope drum is MS fabricated and designed to withstand required nip pressure and provided with Doctoring arrangement.
- Framing is Heavy Duty in Cast Iron construction.

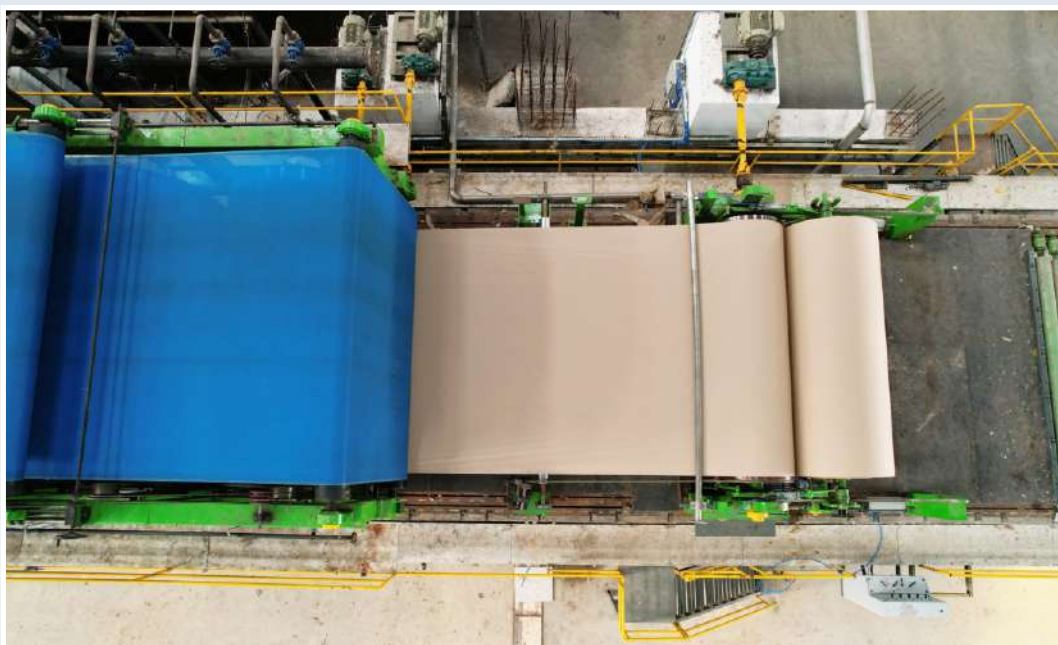

REWINDER

- Heavy Duty Rewinder for trimming and rewinding of Paper Web in required Reel Size.
- Rewinding is done by friction on double drum rolls duly loaded with chrome coated Rider Roll.
- Slitting arrangement is provided with pneumatically loaded trimming knives.
- MS fabricated with frame proper stiffeners with Cast Iron Slide rail.
- Rider Roll is pneumatically balanced.
- Pusher roll for dislodging the rewound roll on collecting table.
- Pneumatically operated braking arrangement.
- Trim Handling system is provided with Blower and Dual Ventury.
- Maximum operating speed is upto 500 MPM and driven by DC/AC variable speed drive.





SOLE PLATE

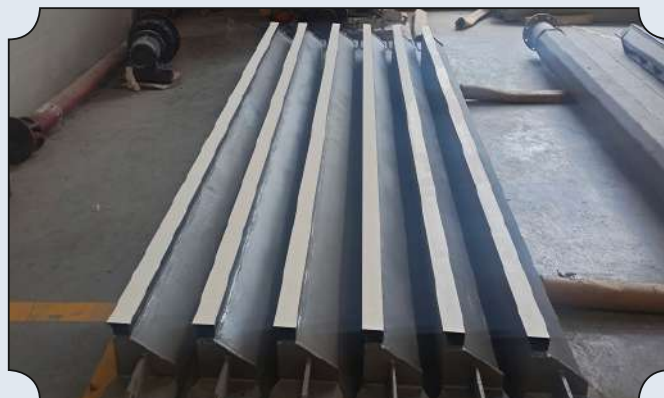

VACCUM BOX



SECTIONAL DRIVE

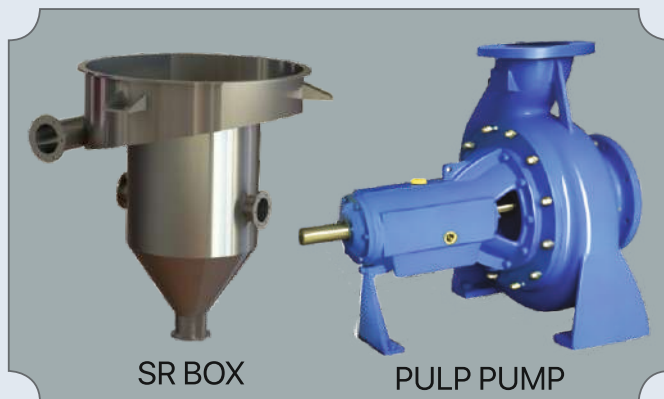

SR BOX

PULP PUMP



VACCUM PUMP



SLAT CONVEYOR



AUTO GUIDE



STRETCHER

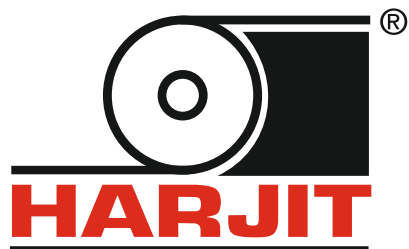

an ISO 9001 : 2015 Company

Harjit Paper & Machinery Pvt. Ltd.

Manufacturers & Exporters of: Paper - Board Mill Machinery

- Office** : 23, 24, Gokal Ka Bagh, 100 Feet Road,
Amritsar-Punjab (INDIA).
- Factory** : Village Bala Chak, Distt. Tarn Taran, Punjab. (INDIA)
- Website** : www.harjitpapermachinery.com
- Email** : harjit_inds@yahoo.com, mail@harjitpapermachinery.com
- Phone Office** : +91-9646911111, 8558888884, 9888039998

